

## Variants

DANLERS design and manufacture other ControlZAPP CZCESRP variants, coded by the following order codes:

CZ CESR	Suitable for mains switching
CZ CESR VF	Suitable for mains switching, Volt Free contacts
CZ CESR 10VDCVF	Suitable for 1-10VDC ballasts, Volt Free contacts
CZ CESR DALI	Suitable for DALI ballasts
CZ CESR DALIVF	Suitable for DALI ballasts, Volt Free contacts

## Troubleshooting

### The load will not switch on:

- The LUX setting as specified by the ControlZAPP App is set too low and is inhibiting the switch.
- The moving body is not emitting more IR than the background.  
(Person wearing insulating clothing in a warm environment)
- Person is too far from the PIR switch, see detection diagram.
- Person is moving unusually slowly (perhaps when testing).
- The control unit battery is not engaged (ON).

Switch RED dip switch next to the telejack connector on the CZ CESR 10VDC control unit towards the centre of the control (see diagram D).

### The load switches on when nobody is present:

- Heater causing infra-red variations in a small cold room.  
Resite the CZ CESR 10VDC control away from heater.
- Please contact DANLERS for further technical support.

## Precautions and Warranty

This product conforms to BS EN 60669-2-1, BS EN 55015 and BS EN 60730.

Please ensure the most recent edition of the appropriate local wiring regulations are observed and suitable protection is provided (protected with the appropriate MCB) 1kV over voltage. Please ensure that this device is disconnected from the supply if an insulation test is made.

This product is covered by a warranty which extends to 5 years from the date of manufacture.

## Products available from DANLERS

- PIR occupancy switches • Daylight linked dimmers • Manual high frequency dimmers
- Photocells • Radio remote controls • Time lag switches • Outdoor security switches
- Dimmers • Heating, ventilation and air-conditioning controls • Bespoke / O.E.M. products

**Please call for more information or a free catalogue, or visit our website.**

DANLERS Limited, Vincients Road, CHIPPENHAM, Wiltshire, SN14 6NQ, UK.

Telephone: +44 (0)1249 443377 Fax: +44 (0)1249 443388

E-mail: sales@danlers.co.uk Web: [www.danlers.co.uk](http://www.danlers.co.uk)

Company Registered Number 2570169 VAT Registration Number 543 5491 38



# DANLERS

## Installation notes

## ControlZAPP Ceiling flush mounted switches

### CZ CESR 10VDC

ControlZAPP ceiling surface passive infra-red occupancy switches (PIR) can be mounted directly onto solid ceilings or onto a range of different mounting boxes (diagram A). These PIR switches incorporate a passive infra-red quad sensor to detect movement of a warm body within their detection zone (diagram B) and a photocell to monitor the ambient light level.

**ALL adjustments are made via a freely downloadable ControlZAPP App available from the DANLERS website.**

If CZ CESR 10VDC is set as PIR with LUX input, upon detecting movement, if the ambient light is dark enough, the ControlZAPP device will turn the load ON. The ambient threshold can be set to between approximately 30 lux to 1000 lux and infinite lux (photocell inactive) via the 'Respond to Daylight' settings on the ControlZAPP App.

If no more movement is detected within a pre-selected time as determined by the ControlZAPP App, then the ControlZAPP device will turn the load off. This 'Time Off Timeout' or time lag can be set via the ControlZAPP App adjuster between 10sec and 23hrs 59min 59sec.

## Loading

CZ CESR 10VDC is suitable for switching and dimming 1-10VDC ballasts. CZ CESR 10VDC can control up to 20mA, eg. 20 ballasts at 1mA (varies according to make and model of ballasts).

CZ CESR 10VDC can also switch up to:

- 10 amps (3000W) of resistive loads
- 6 amps (1500W) fluorescent lamps, high frequency or switch start, incandescent or mains halogen lamps (recommended with integral safety fuse)
- 3 amps (750W) of electronic or wire wound transformers.
- 2 amps (500W) of low energy lamps: CFL, LED, 2D etc.
- 1 amp (250W) of fans or most metal halide lamps.

## Start-up mode and Default settings

When the CZ CESR 10VDC is powered up, it will take 1 minute for the circuitry to stabilise (detection LED flashing) and ensure the output is off, the CZ CESR 10VDC will then enter its Default Operating Mode.

**Please Note:** When in the Default Operating Mode the CZ CESR 10VDC is set up as an occupancy switch with a 20 minute turn OFF timeout (time lag) and photocell disabled.

## Installation procedure

1. Please read these notes carefully before commencing work. In case of doubt please consult a qualified electrician. Ensure wires and cables are securely held within the connection terminals.

**IMPORTANT: The CZ CESR 10VDC Control Unit clock battery must be engaged (ON) prior to installation by switching the RED dip switch (see diagram D) to the DOWN position.**

2. POSITIONING: The CZ CESR 10VDC switch should be installed to achieve correct coverage of the area, see diagram B. If the photocell override facility (enabled via ControlZAPP app) is required, the switch must be located above an area where daylight can give greater illumination than the artificial light. Avoid locating this product where it is exposed to drafty conditions (exposed lobbies, open ceiling voids or near fans) or near heat sources. To cover large areas PIRs should be spaced in a 5 metre grid formation.
3. Disconnect the ControlZAPP device from the circuit before performing insulation testing of the wiring circuit.
4. Do not connect on a circuit with large inductive loads, as induced spikes may cause false triggering or damage the device.
5. CZ CESR 10VDC must be connected to its ControlZAPP Power Supply via the ControlZAPP communication cable provided, for wiring see diagram C.  
NOTE: The use of non ControlZAPP connectors may damage the CZ CESR 10VDC device and will invalidate the warranty.

## Settings and calibration

**NOTE: ALL settings are adjusted by ControlZAPP App as specified in the ControlZAPP App User Guide** (downloadable from the DANLERS website) including: MODE settings, SCHEDULER settings and photocell settings and intelligent photocell calibration procedure.

MODE settings include: Detect Movement (enable or disable), Sensitivity, Short Visit Mode (with timer), Turn ON automatically (Presence detection or Absence detection), Turn OFF timeout (from 10sec to 23hrs 59min 59sec), Respond to Daylight (enabled or disabled) the calibration process must be run for the intelligent photocell to work. Delay before ON or Delay before OFF timers, Scene Recall (ON or OFF).

SCHEDULER settings include:

DAY TYPES (defining times for each of the different Modes to occur).

WEEKLY SCHEDULE (defining which Day Types are assigned to different days of the week).

EXCEPTIONS (defining exceptions to the schedule such as holidays).

VIEW ON CALENDAR (overview of schedule).

## A: Mounting diagram

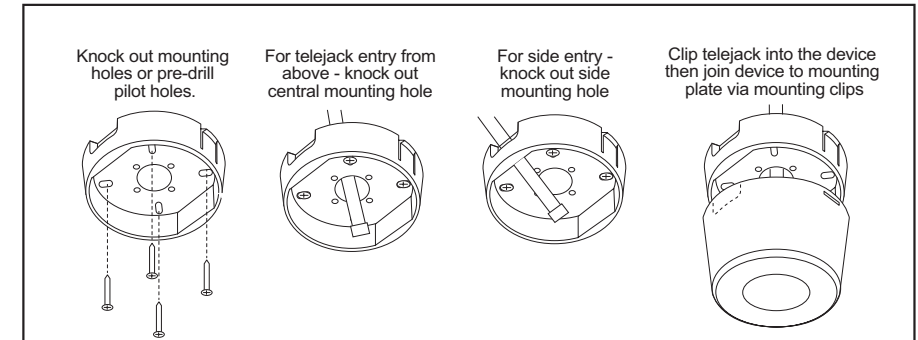

## B: Detection diagram

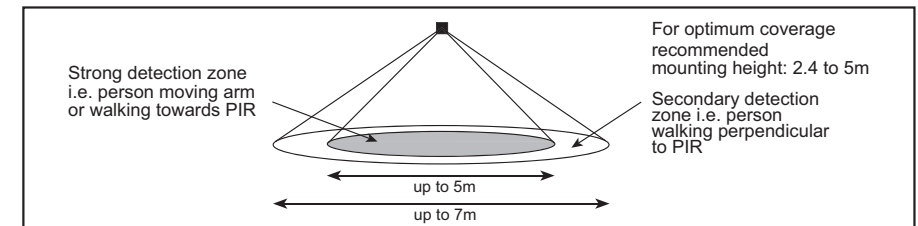

## C: Wiring diagram

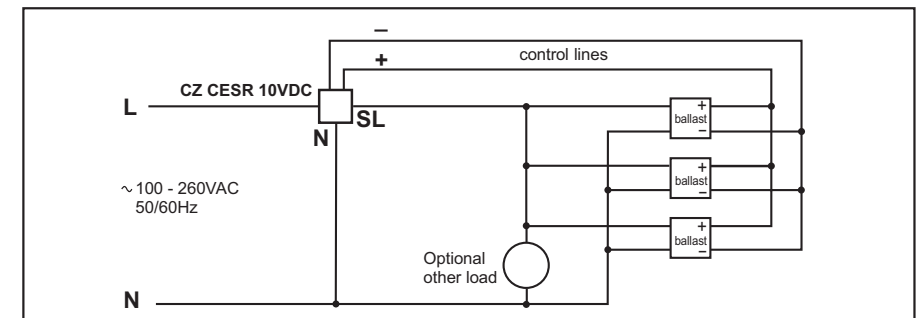

## D: Connector diagram

