

CBU-HBSPDALI

Ceiling High Bay (Spot) Passive Infra Red (PIR) Occupancy Detector & Photocell

Input: 100-240 Vac 50/60Hz

CASAMBI



PLEASE READ THESE INSTRUCTIONS BEFORE INSTALLING THE PRODUCT
NOTE: CBU-HBSPDALI is only compatible to work with Casambi enabled app.

This CBU-HBSPDALI High Bay (Spot Detection) Lighting Control can be mounted directly onto solid ceilings or onto a range of different mounting boxes. Configurable for any room occupancy style, via the Casambi APP on Google Play or Apple APP Store.

INSTALLATION

To be installed by a competent person with reference to BS 7671 or equivalent local standards. If in doubt consult a qualified electrician.

- Plan where the CBU-HBSPDALI is to be located (see diagram 1). Switch off supply and check for hidden cables and pipes.
- The CBU-HBSPDALI should be connected as shown in diagrams 2 and 3:
 - L Live in.
 - N Neutral in.
 - + DALI control line (polarity independent)
 - DALI control line (polarity independent)

- Knockout or drill the appropriate holes on the mounting plate for attaching the plate to the ceiling or back box (if applicable). Feed cables through the appropriate (side or rear) entry hole. Screw the back mounting plate to the ceiling or back box via the mounting holes. Wire the cables into the sensor head block terminal. Push the sensor head onto the mounting plate and align the side clips with the slots on the sensor heads.

OPERATION

To check the operation of the CBU-HBSPDALI:

- Turn on the supply then after 20 seconds if the sensor has recognised movement of a person within its zone of detection the integral red LED on CBU-HBSPDALI will stay illuminated for 4 seconds before the red LED turns off.
- Thereafter, every time movement is detected by CBU-HBSPDALI the integral red LED will stay illuminated for 4 seconds.

The control also features adjustable time out (time lag) control and daylight threshold control which are configured by the Casambi APP.

PRECAUTIONS

- Do not place the CBU-HBSPDALI near heat sources, fans or in ventilated ceiling voids.
- Do not place close to, or positioned such that, any light source points directly into the CBU-HBSPDALI.
- Ensure wires and cables are securely held within the connection terminals.
- The CBU-HBSPDALI should be protected by a 5 or 6 Ampere mcb or fuse.
- Disconnect the CBU-HBSPDALI from the circuit before performing insulation testing of the wiring circuit.**

TECHNICAL DETAILS

INPUT	
Voltage:	100 - 240Vac
Frequency:	50/60Hz
Max. mains current:	20mA
Standby current:	18mA
OUTPUT	
Output:	DALI 15VDC
Output Current:	16mA (maximum 8 ballasts)
RADIO TRANSCEIVER	
Operating frequencies:	2.4... 2,483 GHz
Max. output power:	+4 dBm
LUX PARAMETERS	
Range:	5 - 2000 lux
OPERATING CONDITIONS	
Note: The temperature difference between the detection target and the background must be at least 4 °C.	
Ambient temperature:	-20... +40 °C (Iout 20mA)
Storage temperature:	-25... +75 °C
Max. relative humidity:	0... 80%, non cond.
CONNECTORS	
Terminal block	0,5mm ² - 2,5mm ² solid or stranded
Wire size:	
Wire strip length:	6-7mm
Tightening torque:	0,4 Nm/4 Kgf.cm
MECHANICAL DATA	
Dimensions:	63mm x 90mm x 90mm
Weight:	105g (unpacked)
Degree of protection:	IP20
Protection class:	Built-in Class 2
Material (casing)	Flame-retardant polycarbonate
Finish / Colour	Matt /White (RAL 9003)
Protection class:	Built-in Class 2
CONFORMITY AND STANDARDS	
EMC emission: EN 301 489-1 V2.2.0, EN 301 489-17 V3.1.1, EN 55032: 2015, EN61000-3-2: 2014, EN61000-3-3: 2013	
EMC immunity: EN 301 489-1 V2.2.0, EN 301 489-17 V3.1.1	
Environment: Complies with WEEE and RoHS directives	

5 YEAR WARRANTY

CBU-HBSPDALI comes with a 5 year warranty from the date of manufacture and is CE marked.

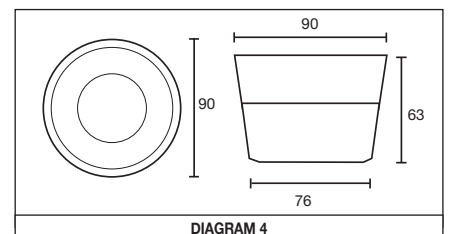
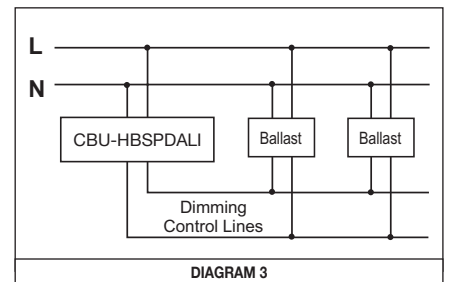
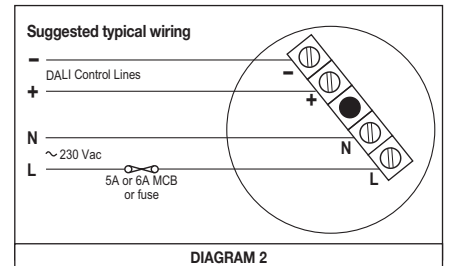
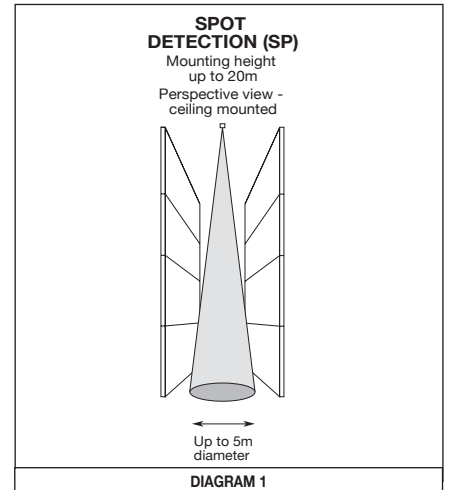

DANLERS Limited, Vincients Road, CHIPPENHAM, Wiltshire, SN14 6NQ, UK.
Telephone: +44 (0)1249 443377 Fax: +44 (0)1249 443388 E-mail: sales@danlers.co.uk
www.danlers.co.uk

Company Registered Number 2570169 VAT Registration Number 543 5491 38

DANLERS